

---

**Types of protection,  
operating modes**

**Type of construction,  
calculation formulars**

**How to order**

**Sales and delivery conditions**

**Contact offices**

The protection types of electrical machines are indicated by a code symbol consisting of two letters and two code figures.

The following protection types are in general use:

## Protection types to DIN EN 60034-5 / VDE 0530 part 5

Protection type	1st code number contact protection	Protection against particles	2nd code number protection against water
IP 00	no protection	no protection	no protection
IP 11	against chance large area contact of inner parts which move or are under voltage	against particles greater than 50 mm diameter	against dripping water vertically from above
IP 23	against contact with fingers	against medium size solid particles greater than 12 mm diameter	against water spray from above max. 60° to vertical
IP 44	against contact with tools, wires thicker than 1 mm	against small solid particles greater than 1 mm diameter	against splashing water from all directions
IP 54	full protection against contact	against damaging dust deposits	against splashing water from all directions
IP 55	full protection against contact	against damaging dust deposits	against water jets from all directions

## Operating modes to DIN EN 60034-1 / VDE 0530 part 1

Code	Nominal operation mode	Details	Additional details	Example
S 1	continuous operation	constant nominal rating possible		
S 2	short time loading	contact nominal rating possible with disconnected pause and complete cooling	connecting time ED in minutes	S 2 – 10 min
S 3	intermittent loading	sequence of uniform short time loadings with disconnected pause for complete cooling	loading duration ED in % of cycle time	S 3 – 40 %
S 4	intermittent operation with influencing by start	sequence of start, constant nominal load and disconnected pause, constantly repeated	loading duration ED in % of cycle time	S 4 – 30 % – 10 cycles/h
S 5	intermittent operation with influencing by start and electrical braking	sequence of start, constant nominal rating, electrical braking and disconnected standstill, constantly repeated	loading duration ED in % of cycle time	S 5 – 20 % – 24 cycles/h
S 6	continuous operation with intermittent loading	sequence of constant nominal rating and idling, constantly repeated	loading duration ED in % of cycle time	S 6 – 60 %
S 7	uninterrupted operation with start and braking	sequence of start, constant nominal loading and electrical braking, no standstill, machine constantly connected		
S 8	uninterrupted operation with pole changing	periods with different loading and speed alternate, without standstill	specified separately for each cycle time, rotating speed and loading case	
S 9	intermittent operation with influencing by start, electrical braking and alternating loading	nonperiodical sequence of start, different loading, speed and rotating sense, electrical braking and disconnected standstill of different duration	conditioned by this operation mode a referring continuous rating value is to find out in order to decide the motor size	

## Designs

Type of construction of  
rotating electric machines

**DIN EN 60034-7  
VDE 0530 amendment 7**

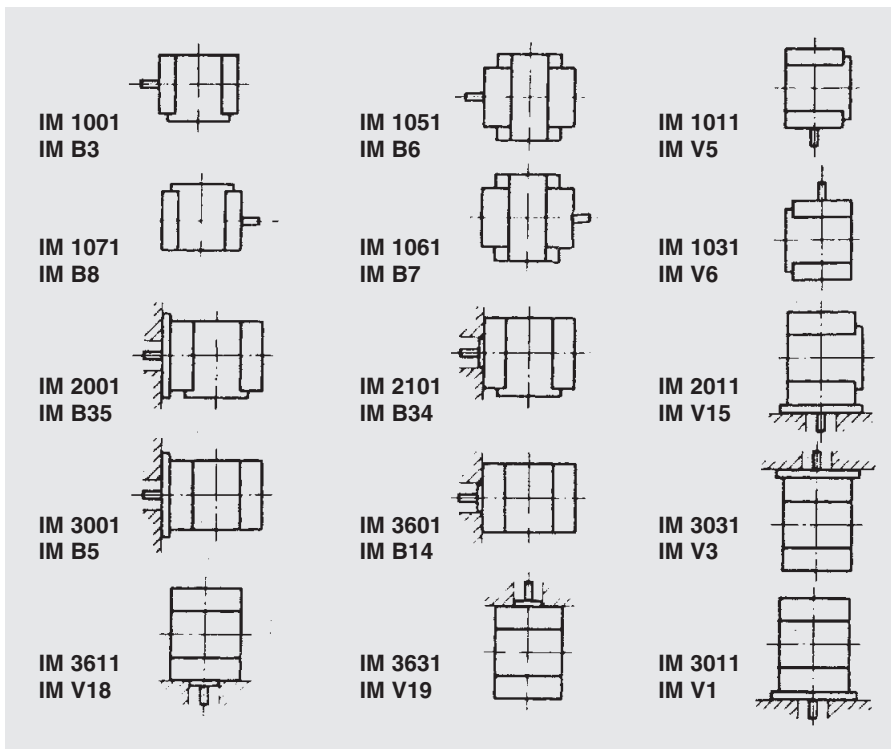

torque:  $M = 9,55 \cdot \frac{P}{n}$

mechanical power:  $P = \frac{1}{9,55} \cdot M \cdot n$

power consumption:  $P_1 = \sqrt{3} \cdot U \cdot I \cdot \cos \varphi$

electrical output:  $P_2 = \sqrt{3} \cdot U \cdot I \cdot \cos \varphi \cdot \eta$

apparent power:  $S = \sqrt{3} \cdot U \cdot I$

nominal current:  $I = \frac{S}{\sqrt{3} \cdot U}$

M = torque [Nm]

P = rating [W]

n = speed [rpm]

$\eta$  = efficiency

$\cos \varphi$  = power factor

U = voltage [V]

I = current [A]

S = apparent power [VA]

## Calculation formulars for drive motors

## How to order spare parts

### principle view of motor main components

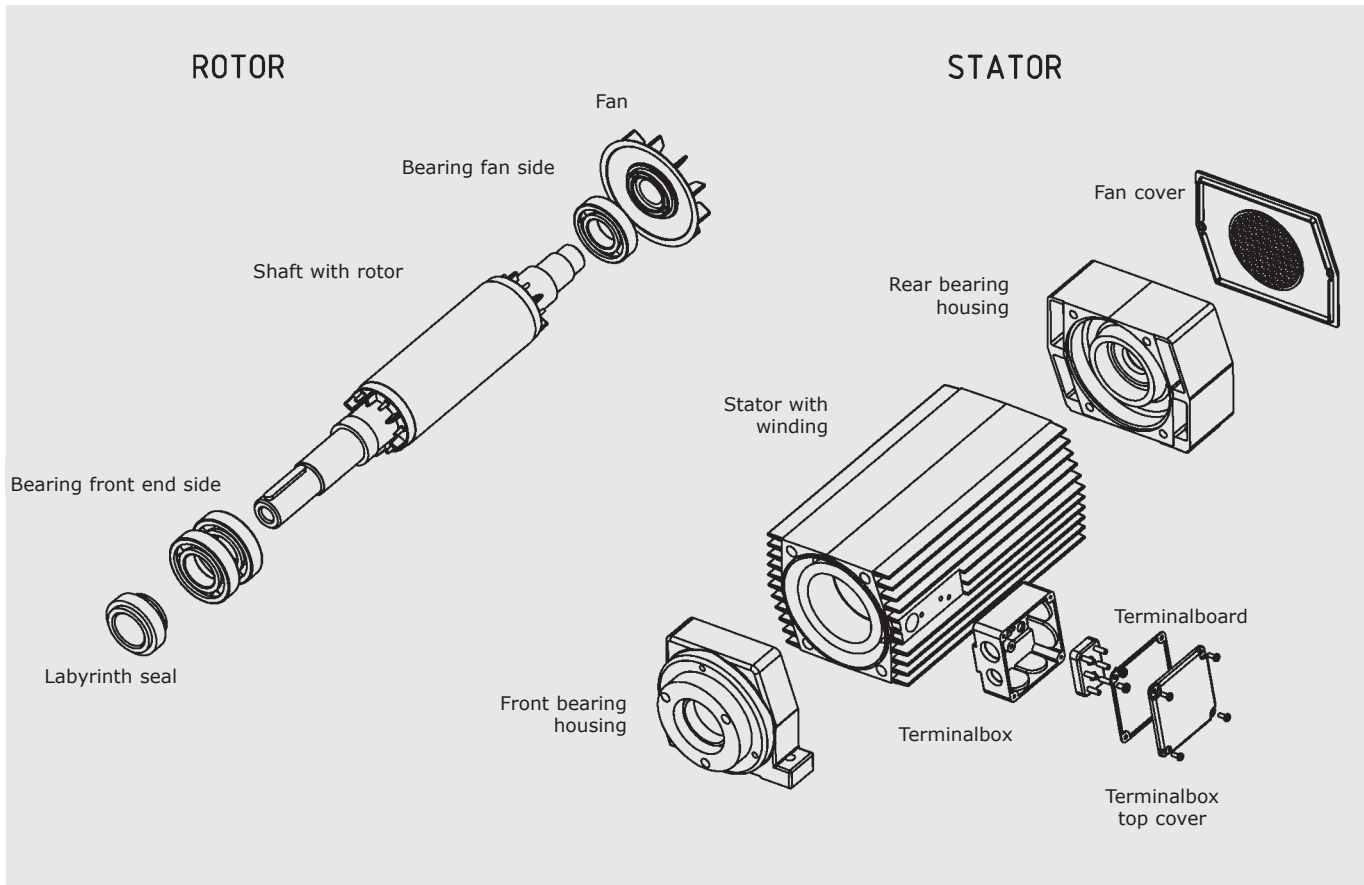

## Attention

**On ordering spare parts please indicate always type and fabrication number (on rating plate).**